

Fourier-based Calculations of Temperatures of Structural Steel in an Environment of Burning Jet Fuel and Office Furnishings

A. K. Dewdney

The University of Western Ontario and
the Scientific Panel Investigating Nine-eleven

Abstract

Structural steel, when exposed to a uniform heat source at temperature T , will, in the absence of conductive, convective, or radiative heat loss, eventually reach the temperature T and remain at that temperature for the duration of the exposure. We calculate the increase in temperature in support columns as a function of time by using the Fourier formula for heat transfer. The formula gives rise to two equations for calculating the temperature in heated steel. The first equation results from treating the formula as a difference equation, an iterative scheme that yields second-by-second changes in temperature. The second equation results from treating the formula as a differential equation, the solution of which yields a formula for temperatures at arbitrary times into the period of a fire. The difference formula approximates the integral formula very closely. Intended as a tool for general heat calculations, the methods are illustrated for box columns and WF columns of varying dimensions and thicknesses. The results of the calculation are then applied to the case of the World Trade Center fuel and office fires on the morning of September 11, 2001.

In addition, an estimate of office fire duration based on burning times of individual items of office furniture is provided. The temperature calculations, fire durations, and other evidence are brought together to demonstrate the extreme unlikelihood of the core columns ever reaching critical temperatures in the World Trade Center on the morning of September 11, 2001.

Introduction

When exposed to fire, a steel support column in a modern office tower will not reach the temperature of the fire instantaneously, but gradually, as a function of the thermal conductivity of the steel, its heat capacity, and the temperature of the fire. Fourier's law [1] provides a convenient tool to estimate the temperature increase in two types of column, a box-column and a WF (wide flange) column. The illustration below shows the cross-section of a typical box column.

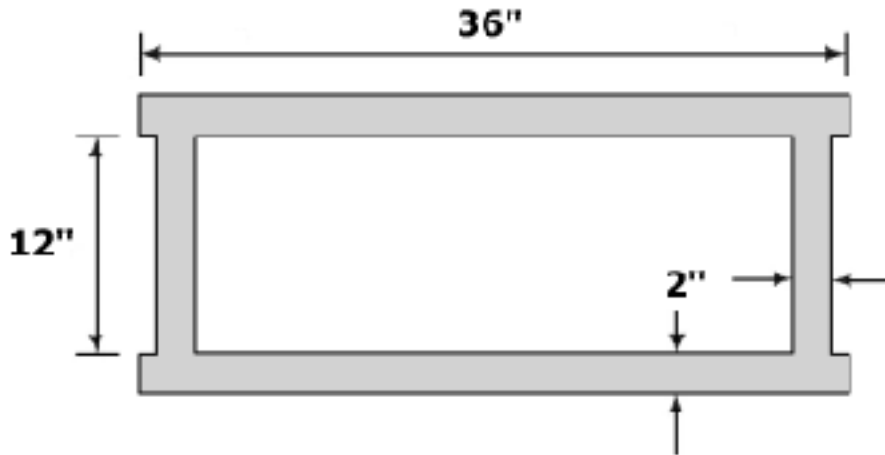

Figure 1. Cross-section of a WTC box column

Fourier's law provides an exact calculation of heat transferred to steel as a function of the difference between the temperature of a column directly exposed to the fire and the temperature inside it -- or on the other side of it. (Alternatively, the calculation can be used for sheet or plate steel in various settings.) For present purposes, the one-dimensional form of the equation [2] is sufficient, since heat is moving in essentially one direction only -- from the outside of a column inward.

$$q = k A \frac{dT}{s} \quad (i)$$

The meanings of the variables and parameters in the formula appear in the table below:

symbol	status	interpretation	units
q	variable	heat transfer per unit time	W -Watts
A	parameter	heat transfer area normal to source	m ² - area in sq. meters
k	parameter	thermal conductivity of material	W/m °C
dT	variable	temperature difference across material	C - degrees celsius
s	parameter	thickness of material	m - meters

Table 1. parameters and variables that appear in the formula

Parameter values remain unchanged during a given calculation, whereas the values of variables may change continually.

Equation (i) is implicitly a differential equation, since the unit of Watts can be expressed as Joules per second (dJ/dt), but it may equally be viewed as a difference equation (Dt), provided that an appropriate time-step is chosen. The smaller the time step, the more accurate the result. In this case, the adoption of a one-second time step, while producing a slight overestimate of the temperature, yields a result that is much closer to the true temperature than would a one-minute time step, for example. Since the unit of Watts is defined as Joules per second, we will accordingly reinterpret q as the number of Joules of heat transferred to the steel over a one-second time period. We therefore rewrite the formula in difference equation form:

$$Dq = k A (T_1 - T_2)/s \quad (ii)$$

Here, I have written q as a heat increment Dq and I have replaced the symbol dT by the more explicit temperature difference $(T_1 - T_2)$, where T_1 is the temperature of the fire and T_2 is the temperature of the air inside the column -- or on the other side of the steel. In due course the variable T_1 will be replaced by the burning temperature of jet-A fuel, i.e. 800°C , approximately.

If we rewrite equation (ii) as a differential,

$$dq/dt = k A (T_1 - T_2)/s,$$

we find that the total heat absorbed by the steel over an arbitrary period of time is given by the indefinite integral,

$$Q = \int dq = \int k A (T_1 - T_2)/s dt$$

This integral will be solved in the next section in the context of a temperature-based (rather than heat-based) formula. The following calculations are based on a test element of steel, the length of which varies as the thickness of steel being investigated. The test element has dimensions of 1 cm x 1 cm x the thickness of the column. It represents what is going on throughout the column as it heats up.

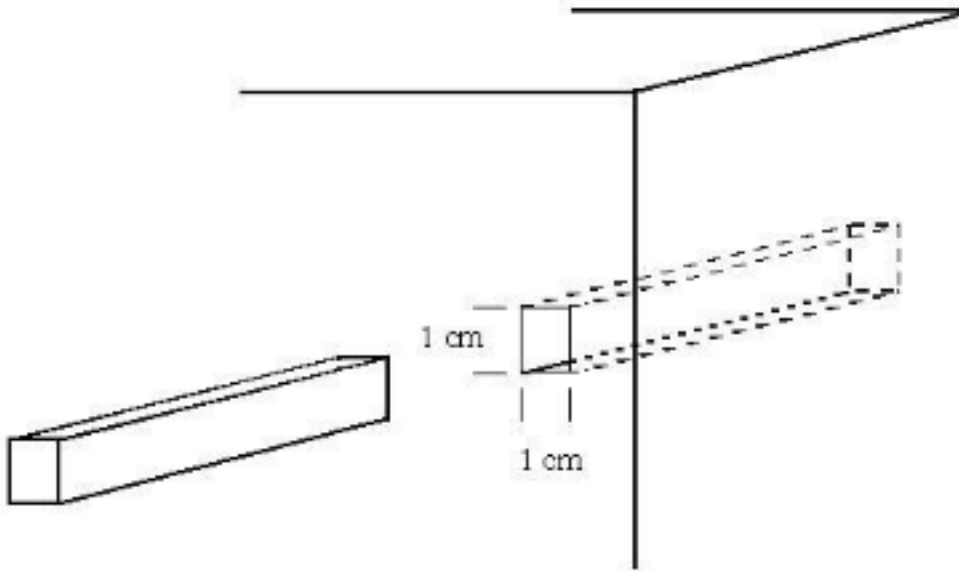

Figure 2. A test element

If the fuel remains unexhausted, the temperature of the column is seen to rise gradually toward a peak temperature -- that of the adjacent fire itself. However, if the fuel becomes exhausted, the peak temperature of the steel is reached at this point. If another, lower-temperature fire invests the steel subsequently, it gradually cools to that temperature.

In the context of the WTC fires, failure to arrive at a calculated temperature sufficient to weaken the steel significantly (initiating collapse) would imply a signal failure of the actual fire to do so. In this spirit, one may list other assumptions behind the calculation that would tend to make it an overestimate:

1. a support column on a given floor is stripped of insulating wallboard and fire-resistant coatings throughout its length,
2. sufficient oxygen is always present to maintain the standard burning temperature of jet fuel throughout the burn period.
3. no heat is conducted away from any column by adjoining steel beams and adjacent columns.

4. Radiation of heat from fires within a given floor follow an inverse-linear, rather than inverse square law.

The purpose of the final assumption is to take into account heat reflected from any floor or ceiling elements still present following the entry of an aircraft into the affected floors. In other words, by treating the fire as a two-dimensional phenomenon (in plan view), one has more than compensated for reflected heat by making *all* the heat generated by burning fuel (or office materials) available for radiation in a horizontal direction. Obviously, an inverse linear law involves higher heat values at a distance than does an inverse square law.

The Temperature Calculation

The following table presents the physical constants that will play a role in the analysis to follow.

constant	value
critical point of steel	550° C [3]
thermal conductivity of steel	46 W/m
specific heat capacity of steel	486 J/(kg x C°)
specific gravity of steel	7850 kg/m ³
burning temperature of kerosene	800° C (open air)

Table 2. Physical constants relevant to the calculation

The critical point of steel is one of the most important factors entering the present analysis. Two such points are defined for structural steel. One is a physical property related to crystallization within steel as it is heated during manufacture. This version of the critical point varies from 900° C for pure iron, dropping to 724° C for low carbon steel, then climbing gradually to about 1100° C for high carbon steel. The other kind of critical point applies to the load-bearing performance of steel as it heats up in a building fire.

The thermal conductivity of structural steel varies with the temperature. At 0° C it is 54 W/m, decreasing linearly to approximately 28 W/m at 800° C. [4] We use a low value for this parameter characteristic of steel at approximately 200° C. Thus at temperatures below 200° C, our steel is conducting heat less rapidly than it should, while above it, our steel heats more rapidly. The compensation point is reached at approximately 400° C. The specific heat capacity figure above applies to steel at 20° C. Above this temperature, the specific heat capacity increases in linear fashion to approximately 850 J/(kg x °C). [4] Use of the constant value for heat capacity means that calculated temperatures are overestimated, in line with the policy spelled out at the end of the foregoing section

In preparation for the calculation, all parameters and constants in the formula,

$$Dq = k A (T_1 - T_2)/s$$

must be replaced by appropriate values. In particular, $(T_1 - T_2)$ becomes $(800 - T_2)$, the temperature T_1 being fixed. The difference equation thus becomes

$$Dq = 46 \times 0.0001 \times (800 - T_2)/0.0508,$$

where 800 is the temperature of the (jet-fuel) fire and the calculation is being made for 2" steel (length of test element is 2" = 0.0508 m). The formula now simplifies to

$$Dq = 0.09055 \times (800 - T_2)$$

We make the formula iterative by converting the heat increment (Dq) into a temperature increment. To do this, we must divide Dq by the product of the mass of the test element and the specific heat of steel. (the amount of heat required to raise the temperature of the test element by one degree Kelvin -- or °C). The mass of the test element is simply its volume multiplied by the specific gravity of steel:

$$\text{mass} = 0.0508 \times 10^{-4} \times 7850 = 0.03988 \text{ kg}$$

The temperature increase in the test element is then obtained by dividing Dq by $0.03988 \times 486 = 19.3817$. The variable T (replacing T_2 for the duration) represents the temperature of the test element as the result of heat taken up by it.

$$DT = Dq/19.3817 \text{ } ^\circ\text{C}$$

The heat equation has thus been transformed into an iterative temperature equation. To get the next temperature T, we perform the addition shown in the second part of the following iterative scheme:

$$DT = 4.6719 \times 10^{-3} \times (800 - T)$$

(iii)

$$T = T + DT$$

The iterative calculation begins by assuming an initial temperature of 20° C in the test element. This figure is a nominal average daytime temperature for the period (September 11 2001) in question. For the first second of the jet-fuel fire we have the following increase in temperature in the test element:

$$DT = 4.67193 \times 10^{-3} \times (800 - 20)$$

$$= 3.64411 \text{ } ^\circ\text{C}$$

$$T = 20.0000 + 3.64411 = 23.64411 \text{ } ^\circ\text{C}$$

after one second the temperature in the steel has risen from 20.00° C to 23.6° C. Throughout the calculation we will carry five decimal digits of precision, using the usual rounding formula. (1 to 4 => 0; 5 to 9 => 1)

The rise in temperature over the next second is carried out in similar fashion, with the temperature difference (800 - T) now reduced from 780° C to 776.3° C:

$$DT = 4.67193 \times 10^{-3} \times 776.35589$$

$$= 3.62708 \text{ } ^\circ\text{C}$$

$$T = 23.64411 + 3.62708 \text{ } ^\circ\text{C}$$

$$= 27.27119 \text{ } ^\circ\text{C}$$

Clearly, the rise in temperature over each subsequent second during the burning period will not exceed the increments just calculated, but fall steadily shorter, since (800 - T) is continually decreasing. Table 3 (below) gives the temperatures of the test element over the first ten seconds, and at 10-second intervals after that, as calculated by this method:

time (sec)	temperature (° C)	time (sec)	temperature (° C)
1	20.0	20	89.7
2	23.6	30	121.6
3	27.3	40	152.7
4	30.9	50	182.3
5	34.5	60	210.6
6	38.1	70	237.5
7	41.6	80	261.3
8	45.2	90	258.8
9	48.7	100	309.4
10	52.2	110	331.2

Table 3. Temperatures for a box column of 2” thickness

The exact formula to be used next arises from a solution of the integral equation implicit in formula (i). However, to avoid going through the previous development, it is simplest to start with equation (iii), rewriting it as a differential and with the constant reverting to a temporary parameter c:

$$dT(t) = c (800 - T(t)) \quad (\text{iv})$$

The boundary condition $T(0) = 20$ implies that the difference $(800 - T(t))$ has an initial value of 780. The unique solution of equation (iv) is a relatively simple exponential function:

$$T(t) = 800 - \exp(-ct + \ln(780)),$$

If we substitute appropriate values for c, namely $c = 0.004672$, the equation becomes

$$T(t) = 800 - \exp(-0.004672.t + 6.65929) \quad (\text{v})$$

and we may check that

$$T(0) = 800 - 780 = 20^\circ \text{ C}$$

while

$$T(10) = 800 - \exp(-0.04672 + 6.65929) = 55.60635$$

Under the earlier iterative scheme, we calculated a value of 55.7 for T(10) and the approximation is clearly a very good one, with the error in the (seconds-based) iterative method being less than 0.2 percent.

We may now apply formula (v) to test elements of varying length (i.e., thickness of steel), to construct a simple temperature table for 2.0”, 1.0” and 0.5” steel.

	2 inch	1 inch	0.5 inch
minutes			
1	210.7	354.7	545.8
2	354.7	545.8	717.2
3	545.8	717.2	773.0
4	717.2	773.0	791.2
5	773.0	791.2	797.1

Table 4. Temperatures (° C) calculated with exact formula

The steel columns of the WTC

Two cases are treated in this section; steel columns in which the heat source is on both sides of the steel and columns in which the heat is applied to just one side. For example, a box column that is heated on all sides still falls into the second category, since there is no fire inside the column. On the other hand, the change in temperature in a WF-column (shaped like the letter capital H in cross section) that is heated from all sides can still be calculated if we treat the interior of the steel as an “other side.” In other words, a WF-column made of 2” steel can be regarded as composed of two layers of 1” steel and the temperature calculation can be applied to one of these layers. Thus the rise in temperature in a one-inch thick box column would be the same as the increase in temperature in a two-inch WF-column assuming, of course, that both are fully exposed to the same heat source. The “effective thickness” of steel will be the thickness expressed in centimeters (cm) for box columns and the half-thickness (cm) for WF-columns.

We turn now to the north and south towers of the World Trade Center and examine the steel support columns involved in either crash. The plane striking the north tower entered between floors 94 and 98. The plane striking the south tower entered between floors 77 and 83. The data in the table below pertain to floors 83 to 86 of either tower, as given in the NIST report. [5]

Specifically, the thicknesses of the support columns, as given by the NIST report, appear in

Table 6 below. The columns are arranged in three concentric rectangles or tiers, an outer, a middle and an inner. The thicker columns are concentrated in the outer rectangle, while thinner ones are all in the inner rectangles. Under the headings “box columns” and “WF-columns” the entries refer to the thickness of steel used -- in inches. For each column type and thickness, the table lists the number of columns of that type, their position within the core and their effective thickness (in centimeters), as explained above.

	tier	number	effective thickness (cm)
box columns			
1.31”	outer	4	3.3
1.31”	inner	1	3.3
1.50”	outer	4	3.8
1.50”	middle	1	3.8
WF columns			
4.91”	outer	16	6.2
1.62”	middle	16	2.1
0.64”	inner	6	0.8

Table 5. Column types and effective thickness (floors 83 to 86)

The next table gives the temperatures reached within each type and thickness of core column at times $t = 1, 2, 3, 4,$ and 5 minutes, as calculated by the exact formula arising from the differential equation. In addition, temperatures reached in 79 seconds also appear there, as this is the only serious estimate of the duration of the jet-fuel fire.

time	thickness: (cm)	0.8	2.1	3.3	3.8	6.2
1 minute		799.9	648.4	399.3	327.5	153.9
79 seconds		800.0	709.7	<u>475.3</u>	403.3	189.7
2 minutes		800.0	770.5	594.1	<u>513.6</u>	265.1
3 minutes		800.0	794.3	694.9	626.5	356.9
4 minutes		800.0	798.9	745.7	694.9	433.0
5 minutes		800.0	799.8	772.1	736.3	496.0

Table 6. Temperatures of support columns over time

As an indication of relative immunity to the threat of collapse, I have underlined table entries at and below which all temperatures are less than 550°C. There would be little danger that a support column below 550° C would fail. At this temperature, structural steels retain approximately 60% of their bearing strength [4], a factor that is allowed for in structural steel design through redundancy of support members. The thickest column type, even after a five-minute burn, would be immune to collapse, whereas the next thickest column type would be approaching 800° C. The thinnest type of column would arrive at the fire temperature much earlier. (But see next section.)

The following time considerations are also important. They include an estimate of burning time for the jet fuel, as well as elapsed times between the plane strikes and the respective collapses:

location	time to collapse	source
north tower	102 minutes	[6]
south tower	56 minutes	[6]
burning time	“few minutes”	[7]
	5 minutes	[8]
	< 5 minutes	[9]
	79 seconds	[10]

Table 7. Time factors relevant to the calculation

We shall address the jet-fuel burn-time estimates first. The figure of “less than five minutes” given by the FEMA assumes that all 10,000 gallons of jet fuel was “evenly spread across a single building floor,” forming “a pool that would be consumed by fire in less than 5 minutes.” The same assumption is made in a thermodynamic study [8] which arrives at a figure of 5 minutes. However, it would appear likely that a large proportion of the jet fuel was consumed in the initial fireballs resulting from impact. The burn-time estimate by Torero et al. [10] is based on the assumption that 2/3 of the fuel remained as a pool fire. The burning time of this fire, based on standard rates of consumption for a pool fire of that magnitude is 79 seconds. [10] A guess by the NIST of a “few minutes” is mere arm-waving and can be discounted as essentially useless.

Taking the most realistic burn-time figure of 79 seconds, we can see from Table 6 that only a support column of the very lightest steel could have gotten close to the ultimate fuel fire temperature of 800° C. The heavier support columns are all well below their fire-induced failure point of 550° C. The fact that no support columns could have failed either during the jet-fuel fire or immediately following the exhaustion of the fuel is consistent with the fact that the buildings did not collapse in that period. Indeed, any column that was heated by the jet fuel fire would appear to have been cooling off after the first minute or two of impact. Following this period, a number of office fires were burning on the floors affected by the aircraft impacts.

The office fires

The temperature of “typical” office fires are the result of the burning rates of wood, paper, and various synthetics like plastic. It is quite difficult to characterize office fires generally, since they can involve little fuel and poor ventilation (low temperatures) or abundant fuel and a plentiful supply of fresh air (high temperature) or indeed any combination of these factors. In order to rate fireproofing materials, manufacturers use the standard fire curve [11], a simple equation that characterizes a rather hot fire that never goes out. Indeed, one can see from the logarithmic term in the following equation, that the temperature of this fire increases without limit.

$$T = 20 + 345 \times \log_{10}(8t+1)$$

Here, T is temperature in degrees celsius and t is time in minutes.

The fire-rating of an object is not the temperature at which it bursts into flame however, but the amount of time it takes to reach the ignition point for the standard fire curve just given. The temperature of the standard fire must grow without limit in order to ensure that every material must, sooner or later, succumb to its internal heat and begin to burn freely. This way, no material can ever receive an infinite fire rating value.

There can be little doubt, however, that a typical office fire involves temperatures that climb rapidly at first, then at an increasingly slower rate as the fire reaches the maximum burning temperature of the materials involved -- as implied by the Fourier heat formula. The rate then

slows as the fuel becomes exhausted. Then it begins to fall. A more realistic temperature curve would increase to a peak, then drop slowly to ambient levels.

There are data available on the burning characteristics of various items of office furniture. For example a series of upholstered chair experiments [12] clearly demonstrate separate phases through which a piece of burning furniture may go. Thus for the first 80 seconds, a “typical” upholstered armchair that was deliberately ignited in a test chamber entered a “spread” phase during which the fire generated up to 300 kW (kilowatts) of heat. The next phase, “burnthrough,” lasted another 130 seconds while producing the same level of heat. Meanwhile the synthetic materials in the armchair had been melting and forming a pool. The “pool fire” phase lasted some 90 more seconds, during which the heat generated soared to approximately 1000 kW, then declined rapidly to about 600 kW at the beginning of the final phase, “burnout.” It took the fire in the test armchair 180 seconds to die down from 600 kW to essentially 0 kW during this last phase. The fire curve for the test armchair would therefore have the shape indicated and decline to 0 heat output in approximately 480 seconds, or eight minutes.

Similar experiments with a burning (wooden) book case resulted in the end of the burnout phase before 10 minutes had passed. [13]

Most items of office furniture these days have large quantities of plastic (of one kind or another) in them. Many are based on polypropylene, which melts between 320° C and 400° C. [14] In a series of experiments on office computers, keyboards and monitors were consumed in 25 minutes, reaching a peak heat of 250 kW. [15]

Paper and paper products burn at approximately 230 to 250° C, but only when freely permeated by fresh air, as in the burning of a single sheet. A stack or file of papers -- or a book for that matter, would tend to produce a low-temperature “smoldering” fire, one that could nevertheless last for several hours.

In order to assess the effect of the office fires on the WTC structural steel, the heat produced by burning furniture and other materials must be translated into temperature in an exposed support column. In order to address this problem, we must use the conversion employed earlier in the Fourier heat equation. How hot does one kg of steel become when supplied with Q kW of heat over a specified period of time? As seen when we converted heat to temperature in the Fourier equation, one divides the heat by the mass of the steel (1 kg) multiplied by the specific heat (486 J/kg x °C). The result is a figure that tells us the rate of increase in temperature per second.

Thus a 1000 kW fire (as in the case of peak heat for a burning armchair) applied to such a mass of steel, will cause a temperature increase of $1000/486 = 2.058^{\circ}$ C per second. A burning time of 90 sec, as in the duration of peak heat for the burning armchair, would therefore produce a rise in temperature of 185.2° C from ambient, for a maximum temperature of 205.2° C in the kilogram of steel.

In a fully exposed (outer) WF-column of thickness 12.5 cm the cross-sectional area is approximately 1533 cm² and, when multiplied by its floor-to-ceiling length of 350 cm, we obtain an approximate volume for the column of 0.537 cu m. Since one cu m of steel weighs 7850 kg the exposed portion of the column would have a mass of 4212.7 kg.

Consider now the Sky Lounge on the 78th floor of WTC Tower 2 (the south tower). Undoubtedly it had many lounge chairs in it, although how many remained following the aircraft strike is unknown. How many lounge chairs, all burning in the manner of the test just cited, would it take to heat just one column to 205.2° C? The answer is 4212 lounge chairs, a figure which exceeds the probable number originally present by one order of magnitude. If the kilogram of steel had already been heated by direct exposure to the fuel fire to a maximum temperature of 230.9° C (Table 6), it's ultimate temperature would be 230.9 + 185.2 = 416.1° C, again, well below the critical temperature. It would take the same number of burning lounge chairs to heat just one of the 16 columns to this somewhat higher temperature. This simple observation puts the interaction between burning office materials and structural steel into perspective.

At a more realistic level we recognize that there was no magical heat pipeline connecting each piece of burning furniture to its nearest core column. Instead, the heat would be transported by a radiative process, with subsequent losses in radiative heat flux per square meter of exposed surface due to the inverse square law of radiation. As mentioned in the list of assumption in the first section, one may substitute a (more intense) inverse linear law of radiation. This more than compensates for heat reflected from ceilings or floors toward the outer core columns. Thus if we imagine an armchair enclosed by a one-meter wide vertical cylinder, the flux through the walls of the cylinder at peak heat would be 1000 kW, say. The flux per meter of cylinder perimeter would be 1000/p or 318.31 kW per meter of perimeter (as seen in plan view). Ten meters away from the burning chair, the flux would drop to no more than 31.83 kW per meter of perimeter. Thus a burning lounge chair (which we may take as approximately equivalent to an upholstered armchair) ten meters from a fully exposed core column of the kind just analysed would raise the temperature in one kg of steel by $31.84/486 = 0.07^\circ$ C per second. Over the same period of time considered in the previous example, one kg of steel would become 5.9° C hotter than it was before. Applying the same reasoning, it would take 4,212 lounge chairs burning at peak heat 10 meters away from a single WF (outer) column to cause an increase of a mere 6° C .

There are 16 outer tier core columns of the WF-type just analysed. In addition, there are eight box columns, four with an effective thickness of 3.3 cm and four with an effective thickness of 3.8 cm. This would give the box columns approximately half the mass of the WF columns and they would, under the same conditions, heat up at roughly twice the rate. They would therefore experience a rise in temperature of approximately 12° C under the conditions examined in the previous paragraph.

Summary and conclusion

Of the types of office furnishings analysed, the upholstered armchairs (lounge chairs) produced the highest heats. If we now replace each of the armchairs by a) an office partition, b) a desk, c) a bookcase, d) a computer workstation, or e) a filing cabinet full of paper according to the numbers actually present on a given (office) floor, it would surely be the case that 4,212 items is a large enough number to account for all such furnishings. In other words, once an item of furniture is in flames it makes little difference what the item was, once we have replaced it by an item that produces as much or more heat during its burning period. We may assume an average distance of ten meters of all such items from their (respective) nearest core columns. This is obviously a drastic underestimate, given the sheer size of the office space on a single floor of either tower. Consequently, the rise in temperature is a drastic overestimate, in line with the general approach adopted in this analysis.

Finally, the foregoing analyses have been applied to a single column. Spread over the 24 (outer tier) core columns, the total heat thus produced could hardly produce a higher temperature than would be the case with all the heat concentrated on a single column.

Some office fires burn for a long time because they are spreading fires. The WTC fires were different, however, in being initiated everywhere at approximately the same time, owing to the jet fuel spreading rapidly across the open areas (outside the core) like a miniature tidal wave. The rapidly spreading pool fire would undoubtedly have invaded the core service area, as well, running along access corridors and into washrooms, open elevator doors, and down stairwells. There was little flammable material in the service area, being mainly concrete covered with tile, wallboard or carpeting, all fire-resistant. [5]

The great bulk of the heat produced by the office fires was therefore outside the core area. As we have seen, most items of furniture capable of burning would have burst into flame within a minute of the impact. According to the burn time figures we have already seen, most of these would have reached the burnout phase within half an hour. The remaining fires would be smoldering fires that, collectively, would produce large volumes of characteristic thick, dark smoke.

The crucial observation in all of this is that the core columns were all located inside the (core) service area. The core, in plan view, had a rectangular shape (87' x 137') and was divided among the following functional structures: 1. elevators, 2. stairwells (3), 3. AC and heating ducts, 4. storage closets. 5. lavatories.

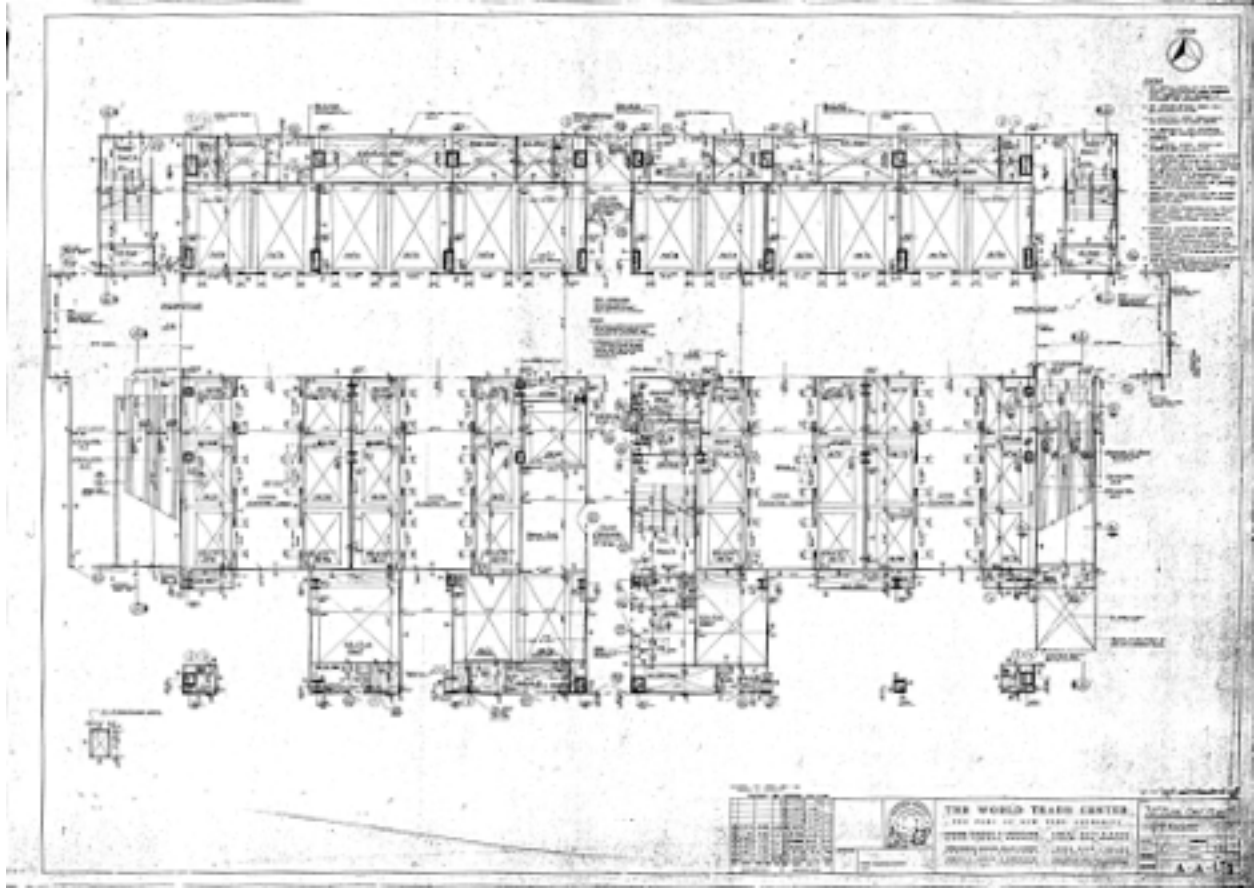

Figure 3. Plan of core service area on floors 83 to 86 of the south tower

Subsequent to fuel burnout, there would be little or no fire within the core area on the affected floors of either tower for the reasons just given. This observation is borne out by the 18 evacuees and fire fighters that passed through the core areas of the south tower by using the stairs, either down or up. None reported excessive heat in the stairwells or corridors. [6]

The inner columns of the cores were the thinner ones that appear in Table 6. Although the table shows them heating most rapidly toward the critical temperature, those are precisely the columns that were largely unaffected by the heat, being far from the office fires and cooling rapidly after the jet fuel pool fire (if they were heated at all). The thicker columns on the core periphery, although closer to the office fires, would have been the slowest to heat up during the fuel fire, none of them having an internal temperature above 475° C and, of course, most (or all) of them well below this.

As we have already seen with the lounge chair demonstration, even if all the heat produced by burning lounge chairs were fed directly and without loss to the outer core columns, they could not have produced enough heat to produce a failure in even one of them.

After approximately half an hour, the (open) office fires would have been dying out one by one, while smoldering fires continued to burn. According to Table 7, the north tower collapsed 102 minutes following impact of the aircraft, while the south tower collapsed in 56 minutes. It follows that, prior to the respective collapses, the north tower had at least (approximately) 72 minutes to cool, entering a regime of steadily falling temperatures. The south tower had about 25 minutes to cool in this sense. As we have already seen, the temperatures in the core columns were well below critical in all cases, in any event. The same observation applies to the distortion in the geometry of the support columns used by proponents of the pancake and related collapse theories to explain the collapse of the twin towers. [16] Any such distortion would have had ample time to enter a correction phase prior to the collapses, leading to the conclusion that no such pancaking could have taken place, even were pancaking floor pans able to induce instantaneous failure in the support columns.

Although the points made above apply equally to both towers (except for the Sky Lounge in the south tower), the plane striking the north tower evidently struck core columns, causing an unknown amount of damage. However, the fuselage of the plane that struck the south tower missed the core completely. Its port wing, however, must have struck a corner column. In the case of such an impact, damage to the column would have been slight, owing to a tendency for wing spars to fail abruptly (snap) when subjected to lateral forces which they were never designed to resist. Wing spars, made from cast aluminum alloy, exert their strength almost entirely in a vertical direction, being configured (in cross section) as a relatively thin vertical rectangle.

The study presented here may pave the way for more detailed analyses of the fuel and office fires in the twin towers. It has provided techniques based on the Fourier heat equation to calculate temperatures in structural steel under varying fire conditions. Further work is also needed on the thermal expansion of steel floor beams in order to assess changes in the (vertical) geometry of the towers prior to collapse.

Acknowledgments

The author thanks Kevin Ryan of the Journal of 9/11 Studies, as well as Michael Armenian of Architects and Engineers for 9/11 Truth, for assistance in locating references.

References

[1] Heat Conduction. 2008. Wikipedia: http://en.wikipedia.org/wiki/Heat_conduction

[2] Conductive Heat Transfer. undated. The Engineering Toolbox:
http://www.engineeringtoolbox.com/conductive-heat-transfer-d_428.html

- [3] Steelwork Fire Resistance. 9/11 Research.
http://911research.wtc7.net/cache/wtc/analysis/fires/steel_fire_resistance.htm
- [4] Structural Fire Engineering. One Stop Shop. 2008
<http://www.mace.manchester.ac.uk/project/research/structures/strucfire/materialInFire/Steel/HotRolledCarbonSteel/thermalProperties.htm>
- [5] Luecke, William E., Stewart, Thomas A., Gayle, Frank W. Sept. 2005. Contemporaneous Structural Steel Specifications, NIST NCSTAR 1-3A, National Institute of Standards and Technology.
- [6] Lewis, Susan K., Nova, Public Broadcasting System. 2008
<http://www.pbs.org/wgbh/nova/wtc/sunder.html>
- [7] Steelwork Fire Resistance. 9/11 Research.
http://911research.wtc7.net/cache/wtc/analysis/fires/steel_fire_resistance.htm
- [8] The jet fuel: how hot did it heat the World Trade Center? Anonymous. undated. 9-11 Research: <http://911research.wtc7.net/mirrors/guardian2/wtc/how-hot.htm>
- [9] Federal Emergency Management agency (FEMA) 2002. World Trade Center Building Performance Study : Data Collection, Preliminary Observations and Recommendations, Washington, D. C.
- [10] Torero, J. L., Quintiere, J. G. and Steinhaus, T. 2002. Fire Safety in High-rise Buildings, Lessons Learned from the WTC. Jahresfachtagung der Vereinigung zur Forderrung des Deutschen Brandschutzetz, V, Dresden, Germany.
<http://www.era.lib.ed.ac.uk/bitstream/1842/1507/1/WTC02.pdf>
- [11] Lennon, T, Moore, D. B., Wang, Y. C. and Bailey, C. G. 2007. Designers Guide to EN 1991-1-2, EN 1992-1-2, EN 1993-1-2 and EN 1994-1-2. Thomas Telford Ltd. London.
- [12] Fleishmann, C. M. Flammability tests for upholstered furniture and mattresses. 2006. in V. B. Apte (Ed.). 2006. Flammability testing of materials used in construction, transport and mining. V. B. Apte (Ed.), CRC Press, Boca Raton.
- [13] NBS 83-2787. 1983. Fire Performance of Furnishings as Measured in the NBS Furniture Calorimeter. Part I, Center for Fire Research, National Bureau of Standards, Washington DC.
- [14] Maier, Clive and Calafut, Teresa. 1998. Polypropylene The Definitive User's Guide and Databook, William Andrew Inc. Norwiuch, NY.

(ANS 2008) Structural Steel, Answers.Com, 2008
<http://www.answers.com/topic/structural-steel?cat=technology>

[15] Bundy, Matthew, Ohlemiller, 2005. Fire Performance of Flame Retarded Polymers Used in Consumer Electronics. NIST, Gaithersburg MD

[16] National Institute of Standards and Technology, 2006. NIST Federal Building and Fire Safety Investigation of the World Trade Center Disaster. FAQ
http://wtc.nist.gov/pubs/factsheets/faqs_8_2006.htm

Notes

North Tower blueprints will be found at at:
<http://911research.wtc7.net/wtc/evidence/plans/table.htm>

Useful information on structural steel will be found at
<http://www.answers.com/topic/structural-steel?cat=technology>

APPENDIX

For those wishing to apply the heat equations used here to other aspects of the WTC fire investigation -- or indeed to any large fire in a steel-frame building -- I have laid out the methods in easy-to-follow steps below:

The heat equation in differential form,

$$dq/dt = k A (T1 - T2)/s,$$

may be converted into the following temperature equation, also in differential form:

$$dT/dt = k A (T1 - T2)/s M h,$$

where M is the mass of the test element, h is the specific heat (486 J/kg x °C), and k is thermal conductivity (46 W/m °C) of steel. A dimensional analysis of the latter formula reveals that

$$J/(\text{sec. m } ^\circ\text{C}) \times \text{m}^2 \times ^\circ\text{C} / (\text{m kg}) \times \text{kg } ^\circ\text{C}/\text{J} = ^\circ\text{C}/\text{sec},$$

so the answer is always given in degrees celsius per second. The equation now becomes:

$$dT/dt = 46 \times 0.0001 \times (800 - T)/w M \times 486,$$

with $M = w \times 0.0001 \times 7850 \text{ (kg/m}^3\text{)} = 0.785 w,$

so that

$$\begin{aligned}dT/dt &= 0.09465 \times 0.0001 \times (800 - T)/ w^2 \times 0.785 \\ &= 0.12057 \times 0.0001 \times (800 - T)/ w^2\end{aligned}$$

Converting this equation to the form of (v), we obtain

$$dT(t) = c (800 - T(t)),$$

where $c = 1.2057 \times 10^{-5}/w^2$, w being the effective thickness of the steel involved.

$$T(t) = 800 - \exp(-ct + \ln(780))$$

and this takes different forms, depending on w , the effective thickness.

w (cm)	w(m)	c
0.8	0.008	0.1884
2.1	0.021	0.0273
3.3	0.033	0.0111
3.8	0.038	0.0084
6.2	0.062	0.0031

The temperature equation for the massive outer WF core columns is therefore.

$$T(t) = 800 - \exp(-0.00314t + \ln(780))$$

or, in a slightly more useful form:

$$T(t) = 800 - \exp(6.659 - 0.0031t)$$

Substituting any time t we like into this equation yields the temperature reached at that time.

Thus the temperature reached after 300 seconds, for example, is given by the following calculation:

$$\begin{aligned}T(60) &= 800 - \exp(6.659 - 0.00314 \times 300) \\&= 800 - \exp(6.659 - 0.942) \\&= 800 - \exp(5.717) \\&= 800 - 304.0 \\&= 496.0^\circ \text{ C}\end{aligned}$$